

TREATMENT OF EMBEDDED GENERATION

Settlement Methodology

Network consumption meters and generation meters will be installed for embedded generators. The settlement methodology for embedded generators is given in the illustrations below.

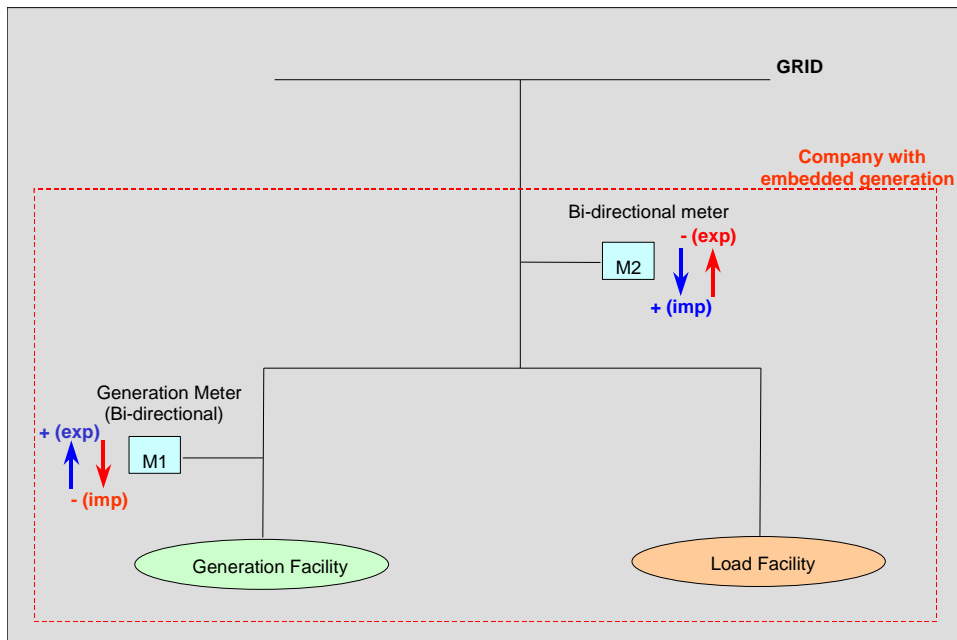

$$M1_{net} = M1_{exp} - M1_{imp}$$

$$M2_{net} = M2_{imp} - M2_{exp}$$

For wholesale settlement calculations under EMC:

(Note: Each group of embedded generation facilities will be assigned one settlement account. The associated load for such group of embedded generation facilities may be assigned the same or another settlement account.)

- $IEQ = M1_{net}$ (Note: The example/diagram above illustrates only one generator for a group of embedded generation facilities. In reality, there can be more than one generator and hence, more than 1 IEQ, for a group of embedded generation facilities. Also, there can be more than one group of embedded generation facilities.)
- $WEQ = \text{sum}(WEQ_{\text{non-EGload}}) + \max(M1_{net} + M2_{net}, 0)$

This refers to the associated load for a group of embedded generation facilities. Again, note that the load can be associated with more than one generator, i.e. there can be more than one IEQ. The example/diagram we use here illustrates only one generator for a group of embedded generation facilities.

- WFQ = Withdrawal Fee Quantity

$$= \text{sum} (\text{WEQ}_{\text{non-EGload}}) + \sum_{\text{(for all EG groups)}} | \max (\sum \text{M1}_{\text{net}} + \text{M2}_{\text{net}}, 0) - \sum \text{M1}_{\text{net}} |$$
- WPQ (refers to the associated load for a group of embedded generator who has been granted price neutralization by EMA) = $\max (\text{M1}_{\text{net}} + \text{M2}_{\text{net}}, 0)$
- WMQ = Withdrawal MEUC Quantity

$$= \text{sum} (\text{WEQ}_{\text{non-EGload}}) + \sum_{\text{(for all EG groups)}} \text{Max}(\max(\text{M1}_{\text{net}} + \text{M2}_{\text{net}}, 0) - \sum \text{M1}_{\text{net}}, 0)$$
- MEUC: based on WMQ
- PSO fees: based on WFQ
- EMC fees: based on WFQ
- IEQ, WEQ, WPQ, WFQ and WMQ are to be computed by MSSL and provided to EMC

(Note that settlement for other charges, e.g. energy, reserve, regulation, HEUC, remains unchanged.)

For MSSL consumer settlement calculations under SPS:

- Retail Market System Related Charge: based on WMQ
- Retail Settlement Uplift: based on WMQ
- $\text{WEQ}_{\text{Retailer}} = \text{WEQ}_{\text{Non-EG}} + (\text{M1}_{\text{net}} + \text{M2}_{\text{net}})_{\text{Retailer-EG}}$

$$\text{WEQ}_h^{\text{MSSL}} = \left[\sum_p E_h^p \cdot \text{ADJ}^p \cdot \text{TLF}^p \right] + \left[\sum_{mp} E_h^{\text{mp} \geq 66\text{kv}} \cdot \text{TLF}^r \right] - \left[\sum_{mp} E_h^{\text{mp} < 66\text{kv}} \cdot \text{TLF}^r \right] + \left[\sum_{mp} E_h^{\text{grf}} \cdot \text{ADJ}^{\text{grf}} \cdot \text{TLF}^{\text{grf}} \right]$$

NUMERICAL EXAMPLES:

Example 1: EG when it is not injecting at end of a 30-min interval

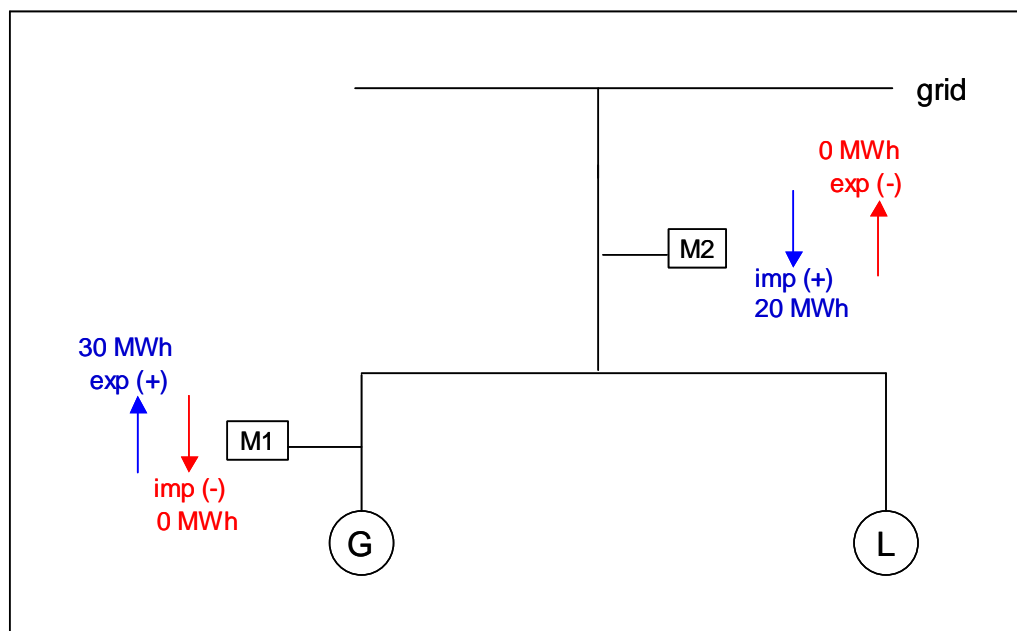

For a 30-min interval,

If: $M1_{exp} = 30\text{MWh}$; $M1_{imp} = 0\text{ MWh}$, $M2_{imp} = 20\text{ MWh}$; $M2_{exp} = 0\text{ MWh}$

then: $M1_{net} = M1_{exp} - M1_{imp} = 30 - 0 = 30\text{ MWh}$

and: $M2_{net} = M2_{imp} - M2_{exp} = 20 - 0 = 20\text{ MWh}$

$IEQ = M1_{net} = 30\text{ MWh}$

$WEQ_{EG} = \max (M1_{net} + M2_{net}, 0) = (30) + (20) = 50\text{ MWh}$

$WFQ = |WEQ - M1_{net}| = 50 - 30 = 20\text{ MWh}$

$WMQ = \max (WEQ - M1_{net}, 0) = \max (50-30, 0) = 20\text{ MWh}$

Charge	Allocation to:	
	Generation	Load
Energy	gets paid for 30 MWh (IEQ)	pays for 50 MWh (WEQ)
UOS	-	$M2_{imp} = 20\text{ MWh}$
SR	scheduled generation and according to the "modified runway method"	-
RR	$ \min (5\text{MWh}, M1_{net}) = 5\text{ MWh}$	$WEQ = 50\text{ MWh}$
EMC Fee	-	$WFQ = 20\text{ MWh}$
PSO Fee	-	$WFQ = 20\text{ MWh}$
MSS Charge	-	$WMQ = 20\text{ MWh}$
MEUC	-	$WMQ = 20\text{ MWh}$

Example 2: EG when it is injecting at end of a 30-min interval

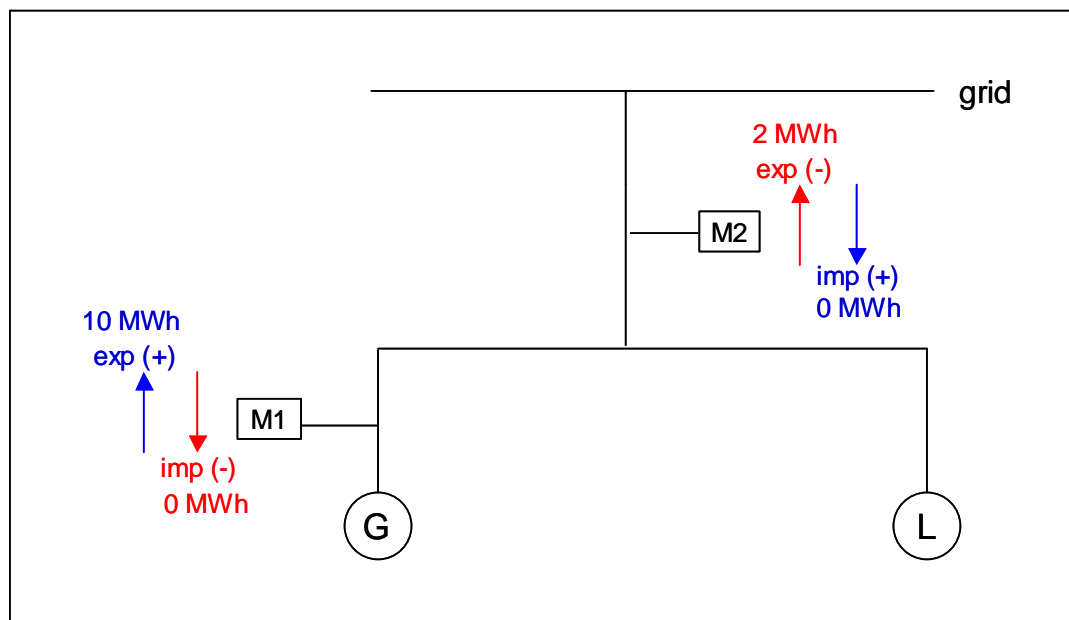

For a 30-min interval,

If: $M1_{exp} = 10 \text{ MWh}$; $M1_{imp} = 0 \text{ MWh}$; $M2_{imp} = 0 \text{ MWh}$; $M2_{exp} = 2 \text{ MWh}$;

then: $M1_{net} = M1_{exp} - M1_{imp} = 10 - 0 = 10 \text{ MWh}$

and: $M2_{net} = M2_{imp} - M2_{exp} = 0 - 2 = -2 \text{ MWh}$

$IEQ = M1_{net} = 10 \text{ MWh}$

$WEQ_{EG} = \max(M1_{net} + M2_{net}, 0) = (10) + (-2) = 8 \text{ MWh}$

$WFQ = |WEQ - M1_{net}| = |8 - 10| = 2 \text{ MWh}$

$WMQ = \max(WEQ - M1_{net}, 0) = (8 - 10, 0) = 0 \text{ MWh}$

Charge	Allocation to:	
	Generation	Load
Energy	gets paid for 10 MWh (IEQ)	pays for 8 MWh (WEQ)
UOS	-	$M2_{imp} = 0$
SR	scheduled generation and according to the "modified runway method"	-
RR	$ \min(5 \text{ MWh}, M1_{net}) = 5 \text{ MWh}$	$WEQ = 8 \text{ MWh}$
EMC Fee	$WFQ = 2 \text{ MWh}$	-
PSO Fee	$WFQ = 2 \text{ MWh}$	-
MSS Charge	-	$WMQ = 0 \text{ MWh}$
MEUC	-	$WMQ = 0 \text{ MWh}$

Example 3: EG under maintenance and not injecting at end of a 30-min interval with negative IEQ

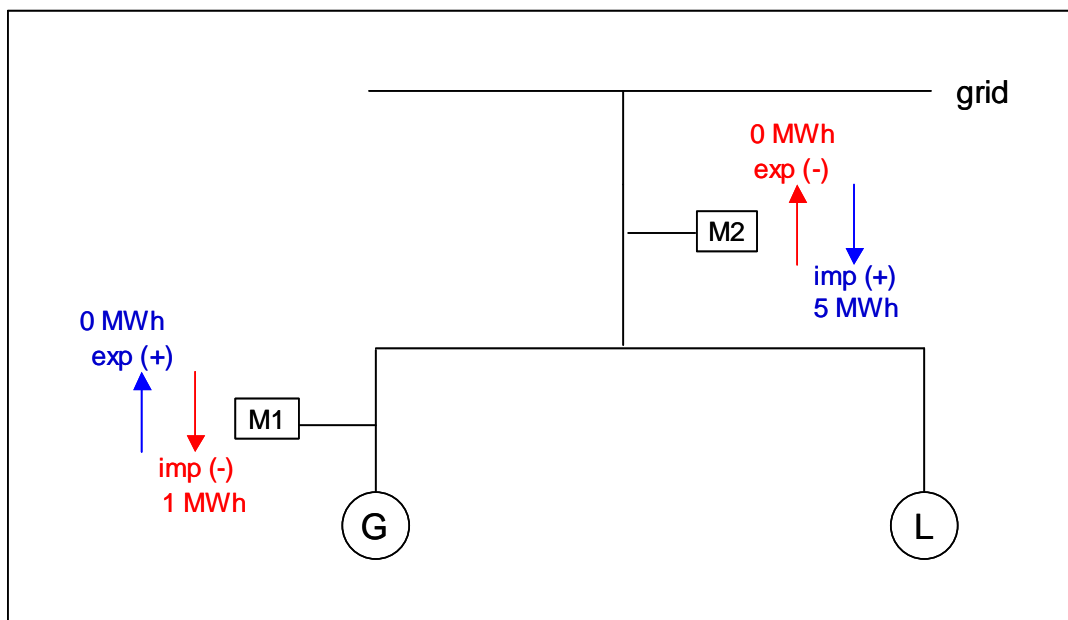

For a 30-min interval,

If: $M1_{exp} = 0 \text{ MWh}$; $M1_{imp} = 1 \text{ MWh}$, $M2_{imp} = 5 \text{ MWh}$; $M2_{exp} = 0 \text{ MWh}$;

then: $M1_{net} = M1_{exp} - M1_{imp} = 0 - 1 = -1 \text{ MWh}$

and: $M2_{net} = M2_{imp} - M2_{exp} = 5 - 0 = 5 \text{ MWh}$

$$IEQ = M1_{net} = -1 \text{ MWh}$$

$$WEQ_{EG} = \max (M1_{net} + M2_{net}, 0) = -1 + 5 = 4 \text{ MWh}$$

$$WFQ = |WEQ - M1_{net}| = |4 - (-1)| = 5 \text{ MWh}$$

$$WMQ = \max (WEQ - M1_{net}, 0) = \max (4 - (-1), 0) = 5 \text{ MWh}$$

Charge	Allocation to:	
	Generation	Load
Energy	pays for 1 MWh (-IEQ)	pays for 4 MWh (WEQ)
UOS	-	$M2_{imp} = 5 \text{ MWh}$
SR	scheduled generation and according to the "modified runway method"	-
RR	$ \min (5\text{MWh}, M1_{net}) = 1 \text{ MWh}$	$WEQ = 4 \text{ MWh}$
EMC Fee	-	$WFQ = 5 \text{ MWh}$
PSO Fee	-	$WFQ = 5 \text{ MWh}$
MSS Charge	-	$WMQ = 5 \text{ MWh}$
MEUC	-	$WMQ = 5 \text{ MWh}$